



INSTALLATION INSTRUCTIONS

Accessory
**REMOTE ENGINE START
SYSTEM**
P/N 38015-TZ5-A10

Application
2015 MDX

Publications No.
BII 51614
Issue Date
MAY 2014

NOTE: For additional technical information, refer to the vehicle's service manual.

PARTS LIST

Bracket

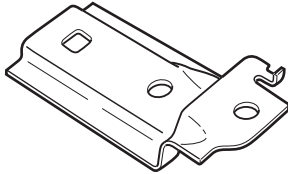

Transceiver

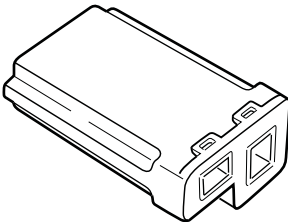

Remote (2)

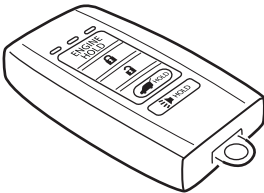

INSTALLATION

Client Information: The information in this installation instruction is intended for use only by skilled technicians who have the proper tools, equipment, and training to correctly and safely add equipment to your vehicle. These procedures should not be attempted by "do-it-yourselfers."

NOTE: Do not damage the headliner.

1. Remove the rear individual map light.

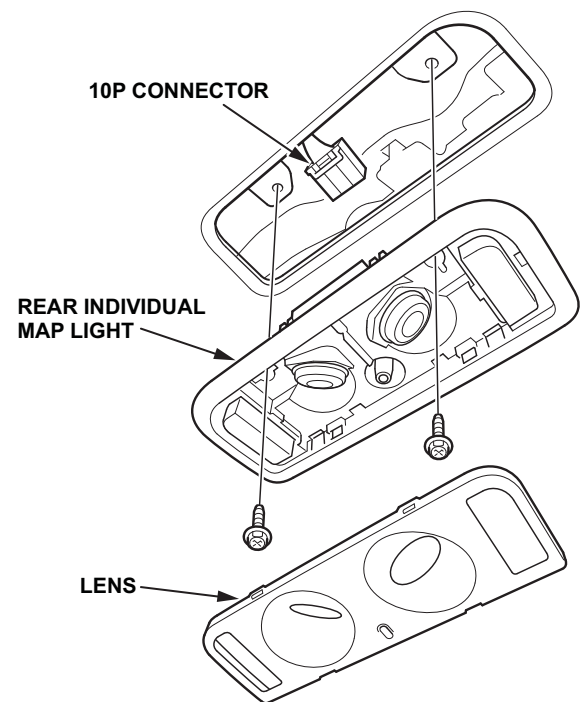

2. Remove the rear tailgate upper trim.

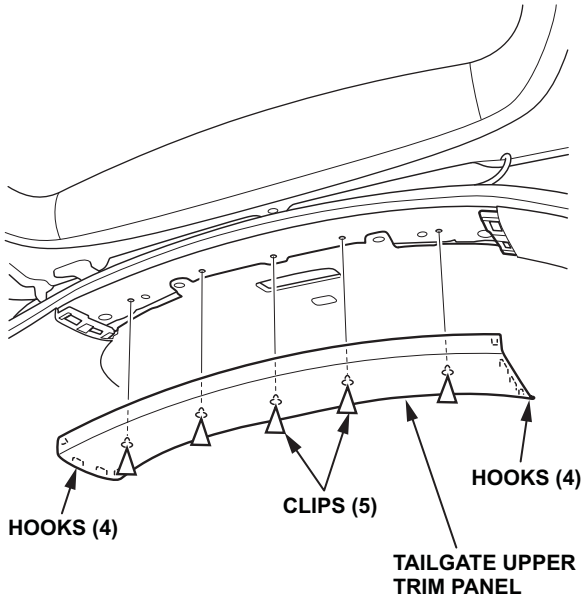

3. Remove the two clips from the headliner as shown .
NOTE: Be careful not to bend or crease the headliner.

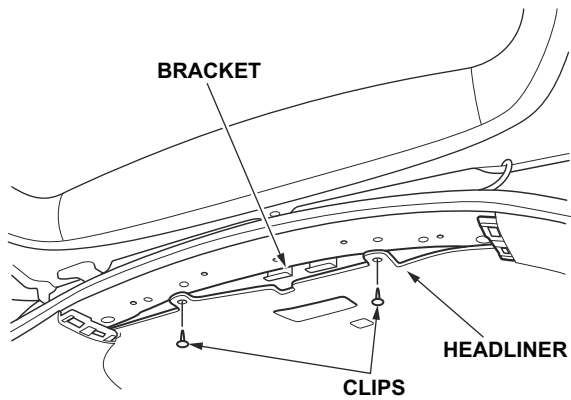

4. Locate the green connector with blue tape, and the black connector with grey tape, then remove the tape to release them.

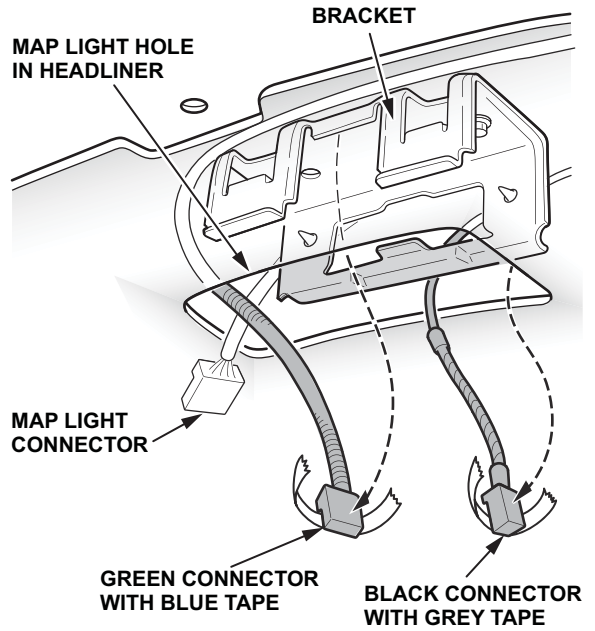

5. Remove the bracket bolt from the bracket.

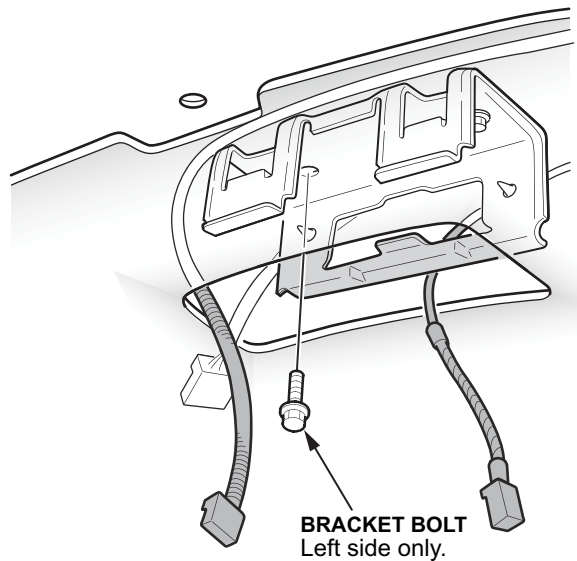

- Slide the transceiver bracket onto the transceiver.

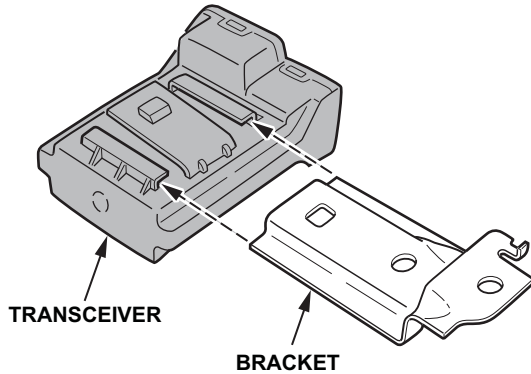

- Connect the black and green connector into the transceiver. Then install the clip on the connector into the hole in the bracket.

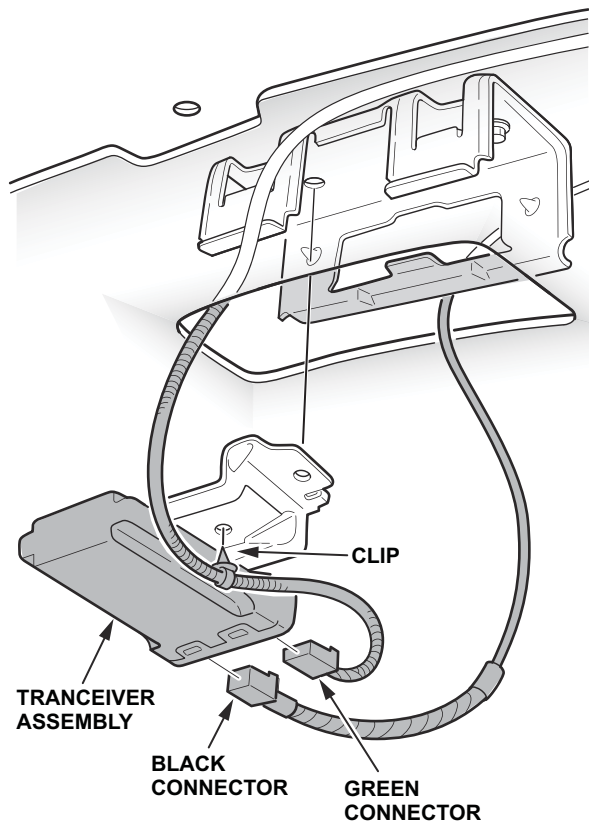

- Using the bracket bolt removed in step 5, install the transceiver and bracket through the rear individual map light area.

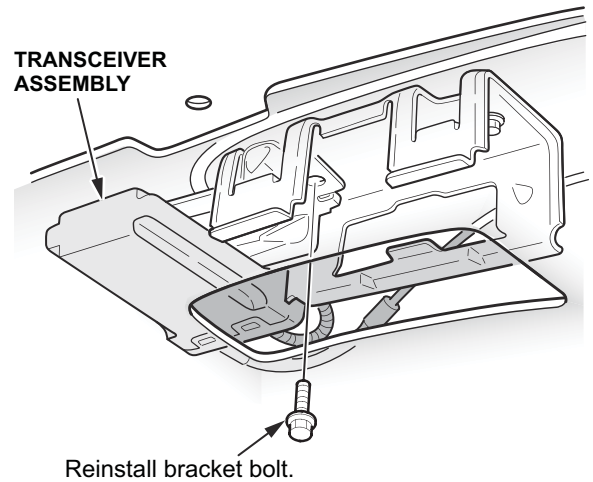

- Reinstall the two clips on the headliner.
- Reinstall the tailgate upper trim panel.
- Reinstall the rear individual map light and torque the bolt to 2.9 N•m (2.1 lbf-ft).

ENGINE REMOTE START SYSTEM REGISTRATION

- Connect the HDS to the data link connector.
- From the System Selection Menu, select ONE-PUSH START, then go to Registration.
- From the Registration Menu, select KEYLESS ACCESS Remotes, then select 2-WAY KEYLESS SETUP. Change the setting to 2-WAY KEYLESS mode. Get the PCM code either through manual mode or automatically through immobilizer code inquiry. Use the original remote, not the Remote Starter remote, and make sure the Remote Starter remote is away from the vehicle.
- Go back to the KEYLESS ACCESS Remotes Registration Menu, select Add a KEYLESS ACCESS Remote, and follow the instructions on the HDS screen. Do not bring the Remote Starter remote into the vehicle until the HDS asks for the new remote.
- Repeat step 4 for the second Remote Starter remote.
- After registration, verify all remote-related systems work normally with all remotes.

REMOTE ENGINE START

1. Press LOCK, then press and hold ENGINE. The amber LED blinks, and the green LED stays solid for one second when the engine starts. You can repeat this once at any time within 10 minutes of the initial remote start for a 10-minute extension.
2. While remote engine start is on:
 - The climate control system can warm or cool the interior, depending on the ambient temperature.
 - The security system remains on.
 - Exterior lights and accessories remain off.
3. To start driving after you enter the vehicle, depress the brake pedal and press ENGINE/START/STOP.

STOPPING THE ENGINE

Press and hold ENGINE. The red LED stays solid for one second.

NOTE: The engine will stop if it has been running for more than 10 minutes or any door is opened without using the remote or keyless access.

For additional technical information, refer to the vehicle's owners manual.